



CAR DOOR REMOVER/INSTALLER JACK

MODEL NO: **MK82**

Thank you for purchasing a Sealey product. Manufactured to a high standard, this product will, if used according to these instructions, and properly maintained, give you years of trouble free performance.

IMPORTANT: PLEASE READ THESE INSTRUCTIONS CAREFULLY. NOTE THE SAFE OPERATIONAL REQUIREMENTS, WARNINGS & CAUTIONS. USE THE PRODUCT CORRECTLY AND WITH CARE FOR THE PURPOSE FOR WHICH IT IS INTENDED. FAILURE TO DO SO MAY CAUSE DAMAGE AND/OR PERSONAL INJURY AND WILL INVALIDATE THE WARRANTY. KEEP THESE INSTRUCTIONS SAFE FOR FUTURE USE.



Refer to instructions



Wear safety footwear



Wear protective clothing



Wear protective gloves



Warning: Pinch crush hazard



Wear Eye protection

1. SAFETY

- WARNING!** Ensure all Health and Safety, local authority, and general workshop practice regulations are strictly adhered to when using this equipment.
- ✓ Before using the stand ensure it is in good working order.
- ✗ **DO NOT** exceed the rated lifting capacity. Overloading may cause equipment failure and serious injury.
- WARNING!** Operate the Car Door Remover/Installer Jack only on firm, level surfaces. Avoid soft ground, slopes, or uneven terrain to prevent tipping or sinking.
- WARNING!** Inspect the Car Door Remover/Installer Jack for visible damage, wear, or malfunction before each use. **DO NOT** operate if any defects are found.
- WARNING!** Ensure adequate clearance around the vehicle to allow for safe operation and to prevent collisions with surrounding objects.
- ✗ **DO NOT** modify or alter the Car Door Remover/Installer Jack. Unauthorised changes can compromise safety and void compliance with safety standards.
- WARNING!** Never ride on the Car Door Remover/Installer Jack.
- ✗ **DO NOT** modify or alter the Car Door Remover/Installer Jack in any way. Lower the load slowly and steadily, maintaining stability at all times to prevent accidents or injury.
- ✓ Inspect thoroughly: Check for worn or damaged parts, casters, support pads. Do not proceed if any issues are found.

2. INTRODUCTION

The jack can lift car doors and large bumpers with ease and can be operated effectively by one person. Padded grips reduce the risk of damage to parts. It offers an adjustable width from 200 to 510 mm and an adjustable height from 170 to 770 mm, with a maximum capacity of 75kg. The unit is fitted with four castors, two of which are lockable.

3. SPECIFICATION

Model No:	MK82
Nett Weight:	21kg
Minimum/Maximum Height:	170/770mm
Minimum/Maximum Width Adjustment:	200/510mm
Maximum Capacity:	75kg

4. FEATURES

1	Rear Locking Castor Wheels
2	Lower Frame Locking Pin
3	Hand Screw for adjusting angle of the Support Arms
4	Winding Handle to adjust height of the Support Arms
5	Support Arms width adjustment
6	Vertical Supports

Also see illustrations overleaf.



MK82

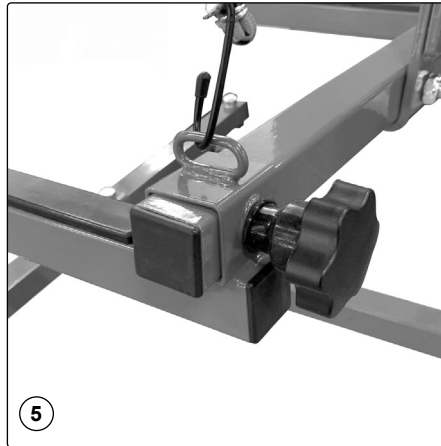
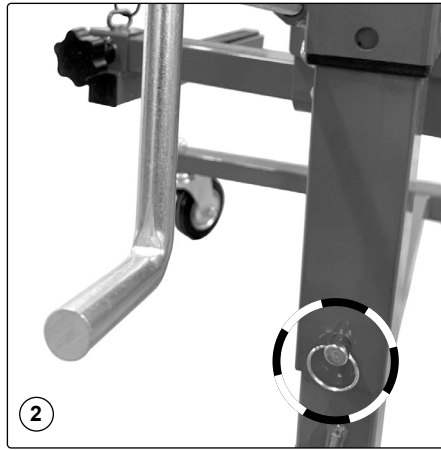
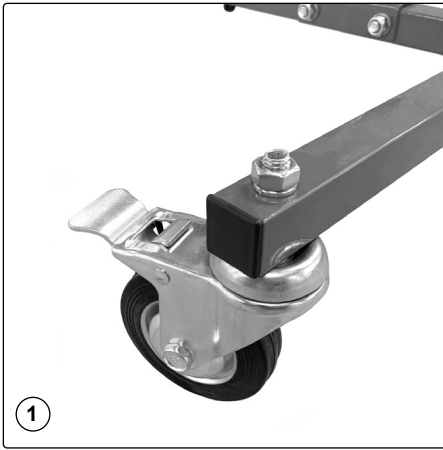

5. ASSEMBLY

- ✓ Get the assistance of a helper during assembly.
 - ✓ Assemble in a large, uncluttered area close to area of intended usage.
 - ✓ Leave fixings loose until assembly is complete then tighten.
 - ✓ Allow sufficient area for operator and helper to remain clear when choosing operating area.
- NOTE:** To protect the finish of the car door remover/installer jack components from damage and scratches, use cardboard, carpet, blankets etc. to cover the area before beginning assembly.
- 5.1. REFER TO PARTS DIAGRAM for assembly starting with the lower support frame first.**
- ❑ **WARNING!** Always wear safety goggles when working with bungee cords.
- 5.2.** Assemble correctly: Follow manufacturer instructions to attach vertical supports, casters, support arms, and tilting beam. Ensure all bolts, washers, and parts are firmly tightened.

6. OPERATION

- 6.1.** Place the vehicle on a stable, level surface (e.g. concrete floor). Engage the parking brake and block the vehicle's tires to prevent movement. Carefully remove or secure any adjacent trim or obstacles so the door can be easily accessed. Position the door lift beneath the door with the support arms aligned under the door's edge or hinge area. Ensure it's centred and well-supported. Use vertical supports and bungee cord, to secure the door in place. Never exceed the specified weight capacity, and never use the lift to raise the vehicle itself.
- 6.2. LIFTING THE DOOR**
- 6.2.1.** Use the winding handle to raise the door to the desired height, typically aligning with hinge position for bolt removal. Adjust the tilting support arms to aid alignment of hinge pins or bolts on the door frame.
- 6.3. REMOVING OR INSTALLING THE DOOR**
- 6.3.1.** With the door held securely, remove hinge bolts.
- 6.3.2.** For installation, align the door using the jack and tilt adjustments, then insert hinge bolts while holding it in place.
- 6.4. LOWERING AND REMOVING THE DOOR**
- 6.4.1.** Once secured or removed, lower the door slowly by turning the winding handle counter-clockwise, doing so gently to avoid sudden drops.
- 6.4.2.** Once lowered, ensure the door is fully supported, then disengage the securing arms before carefully extracting the lift.

7. MAINTENANCE

- 7.4.1.** Before each use, visual inspection shall be made before each use for checking for cracks, cracked welds and/or damaged parts, check the tightness of fasteners. Any Car Door Remover/Installer Jack that appears to be damaged in any way shall be removed from service immediately.
- 7.4.2.** Keep all moving components well lubricated and free of any dirt or debris accumulations.
- 7.4.3.** Clean the Car Door Remover/Installer Jack and protect against rust. Store it fully lowered in a dry place. Replace worn caster wheels if needed.
- 7.4.4.** Note any damage, wear, or unusual operation in a simple logbook to keep track of when service or parts replacement might be due.

7.1. DISPOSAL (END OF PRODUCT LIFE)

- 7.1.1. When the jack has reached the end of its usable life, begin by disassembling it as much as practical so the main steel frame, arms, and threaded parts can be taken to a scrap metal recycler. Rubber or nylon components such as wheels, grips, and pads should be separated and directed to appropriate recycling streams if available, or disposed of in household waste if no recycling option exists. Because the tool is mechanical and contains no fluids, there are no hazardous materials to manage, but it is important to follow local rules for recycling and bulky-item disposal to ensure the equipment is handled responsibly.



ENVIRONMENT PROTECTION

Recycle unwanted materials instead of disposing of them as waste. All tools, accessories and packaging should be sorted, taken to a recycling centre and disposed of in a manner which is compatible with the environment. When the product becomes completely unserviceable and requires disposal, drain any fluids (if applicable) into approved containers and dispose of the product and fluids according to local regulations.

Note: It is our policy to continually improve products and as such we reserve the right to alter data, specifications and component parts without prior notice.

Important: No Liability is accepted for incorrect use of this product.

Warranty: Guarantee is 12 months from purchase date, proof of which is required for any claim.



REGISTER YOUR
PURCHASE HERE

Jack Sealey Ltd t/a Sealey Group, Kempson Way, Suffolk Business Park, Bury St Edmunds, Suffolk, IP32 7AR UK
Jack Sealey (EU) Ltd t/a Sealey Group, Farney Street, Carrickmacross, Co. Monaghan, A81 PK68 Ireland
Tel: 01284 757500 • **Email:** sales@sealey.co.uk • **Web:** www.sealey.co.uk